

DETAIL A

TYPICAL MINIMUM BENDING RADIUS

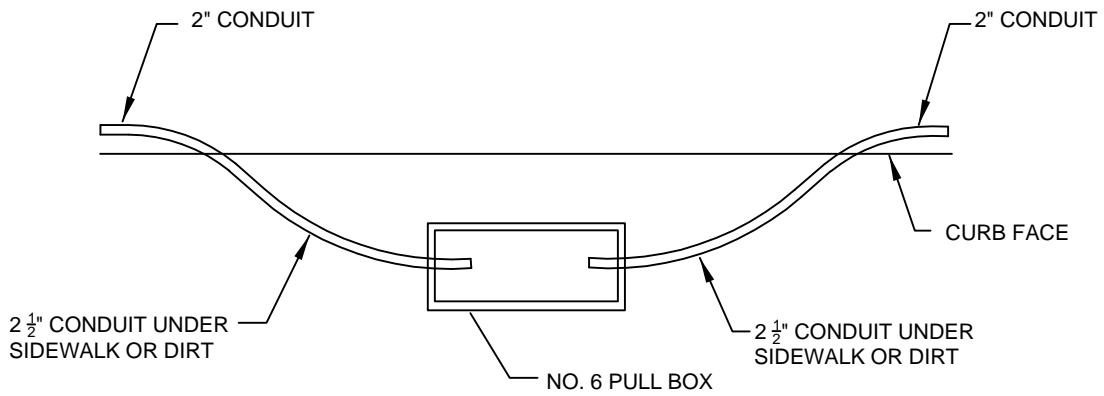

TOP VIEW

ROUTE CONDUIT UNDER CURB & GUTTER INTO PULL BOX

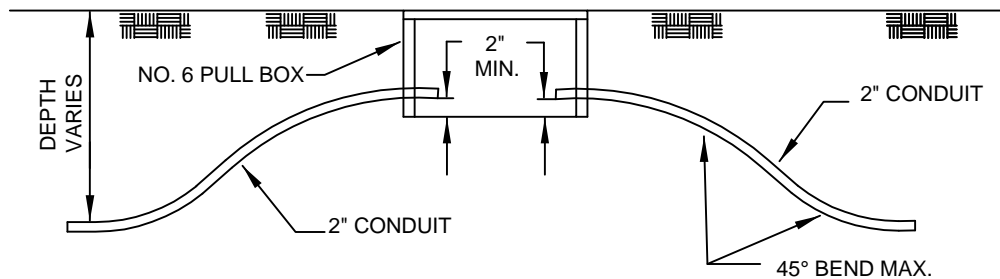

SIDE VIEW

DATE: SEPT. 2001

INTERCONNECT PULL BOX DETAILS

SCALE: NONE

Signature on File
CITY ENGINEER

DEPARTMENT OF PUBLIC WORKS

CITY OF PALM DESERT

STD DRAWING NO.

401