

TYPICAL INSTALLATION
(STREET OR ALLEY)

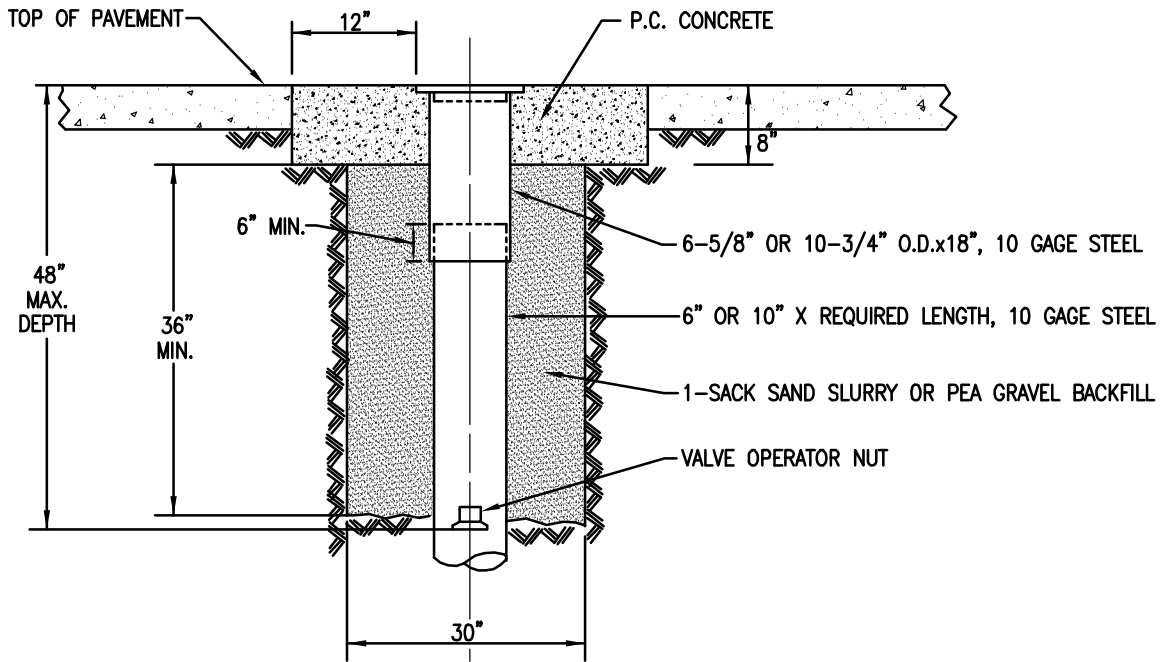

TYPICAL INSTALLATION
(UNTRAVELED AREAS)

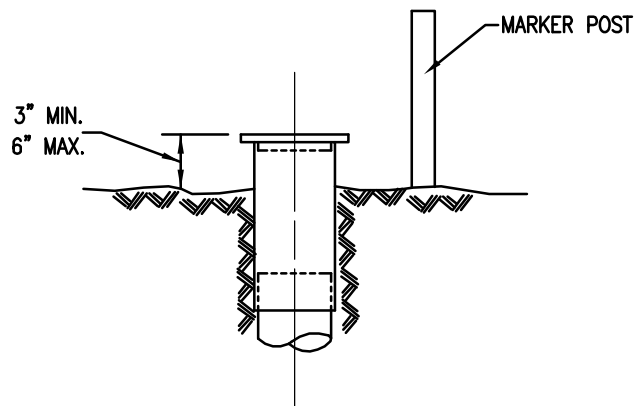

NOTES:

1. ALL CONCRETE SHALL BE 560-C-3250
2. CONCRETE SURFACE SHALL RECEIVE HEAVY BROOM FINISH.

DATE: SEPT. 2001

VALVE OPERATOR WELL INSTALLATION

SCALE: NONE

Signature on File
CITY ENGINEER

DEPARTMENT OF PUBLIC WORKS

CITY OF PALM DESERT

STD DRAWING NO.

109